

# VOLUMETRIC DIVIDER LOFTY

## USE

Automatic dough division for breads and baguettes (volumetric system) from 1,000 to 2,400 pieces / hour.

## CAPACITIES

Model	Diameter piston (mm)	Dough piece weight (g)	
		Min	Max
Lofty 60	60	20	220
Lofty 80	80	30	370
Lofty 100	100	50	700
Lofty 110	110	70	850
Lofty 120	120	90	1000
Lofty 130	130	130	1200
Lofty 140	140	170	1400
Lofty 150	150	200	1650



\* Information given for reference purposes only. It can vary depending on the nature of the dough and the size of the piston and the machine model

## FEATURES

- Volumetric divider with one piston
- **Stainless steel drum**
- **Electronic speed regulation**
- **Electronic weight regulation**
- Height-adjustable **conveyor belt**
- **Electronic dough piece counter**
- Automatic division stop when the chosen number of dough pieces is reached
- **Lubricating System** with filter and sensors
- **Machine on 4 castors**: it enables to move machine quickly and effortlessly.

- **Oil filtering system**: Automatic closed-circuit lubrication of the mechanisms with a recycling process after filtering. As a consequence : low oil consumption.
- **Mechanical variable flow flour duster**: prevents the dough balls from sticking together before loading them into the intermediate proofer.
- **Open stainless steel hopper** with safety ring allowing to feed continuously the hopper without stopping the divider, capacity: 80 to 300kg of dough (80kg, 100kg, 120kg, 150kg, 160kg, 180kg, 200kg, 300kg)

## OPTIONS

- **Closed hopper with automatic opening** with air pressure, stainless steel hopper with the capacity of 200 kg of dough, fast closing and opening. Recommended option to improve the regularity of the weights, specially for doughs that have been fermented before dividing (air compressor not supplied).
- **Volumetric divider with two pistons**
- **Power supply: 220V/3ph**
- **Remote Control Box**
- **Wooden case**

- **2 dough pieces forming systems on exit conveyor (at choice)**:
  - **Pre-rounding dough pieces device**: Allows pre-rounding of previously divided dough pieces before loading them into the intermediate proofer.
  - **MF2S® System** (Stress-free dough pieces rounder): Allows pre-rounding of previously divided dough pieces before loading them into the intermediate proofer. particularly adapted for soft, pointed doughs and Tradition breads.

Z.I. de la Turbanière  
BRECE • 35530 • FRANCE

 +33 (0)2 99 04 15 30

 salesdpt@merand.fr

 www.merand.fr/en/

## PRESENTATION

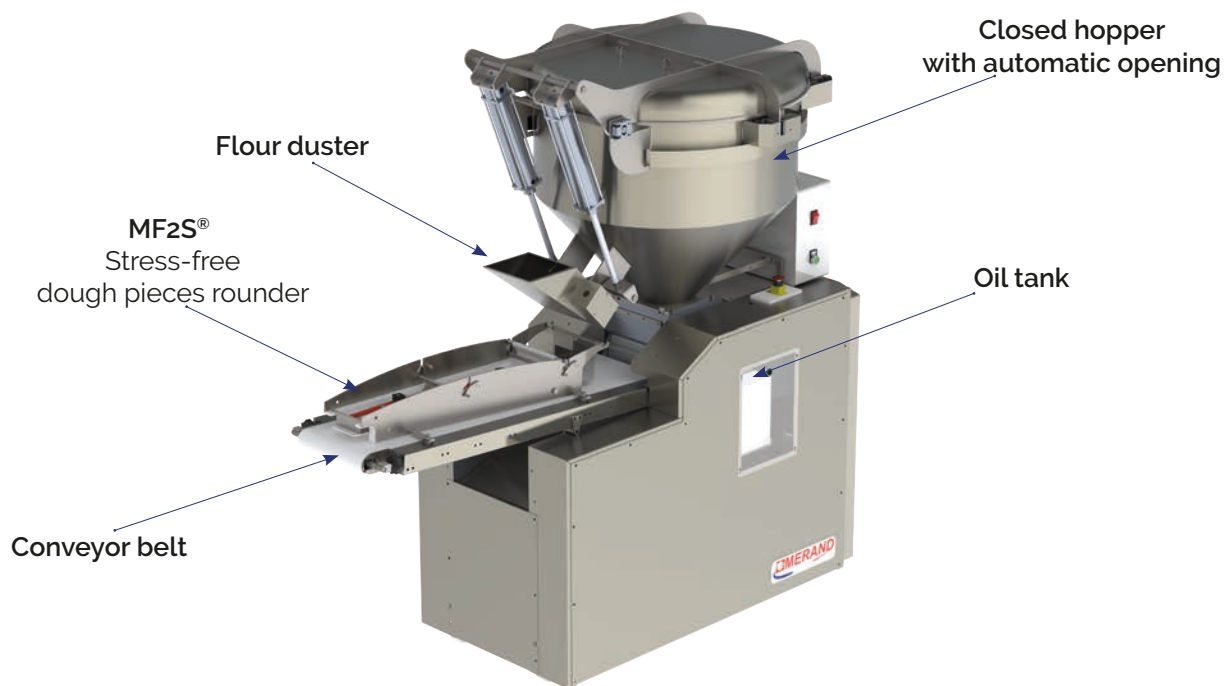

## OVERALL DIMENSIONS (CM)

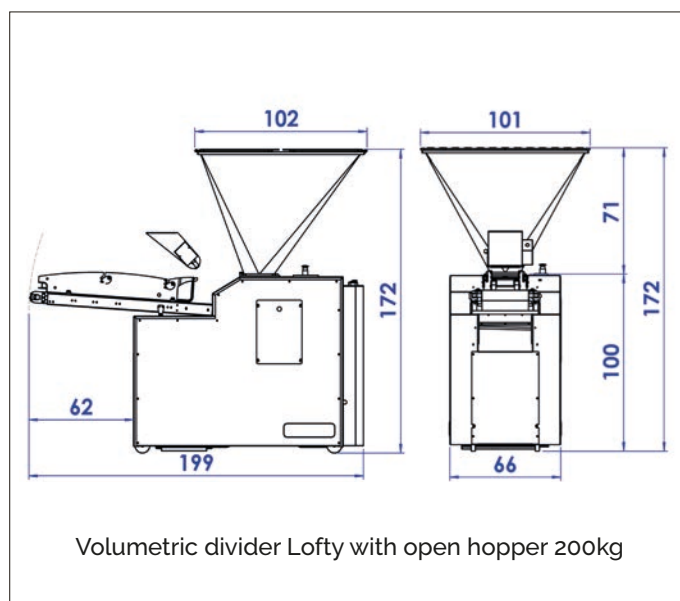
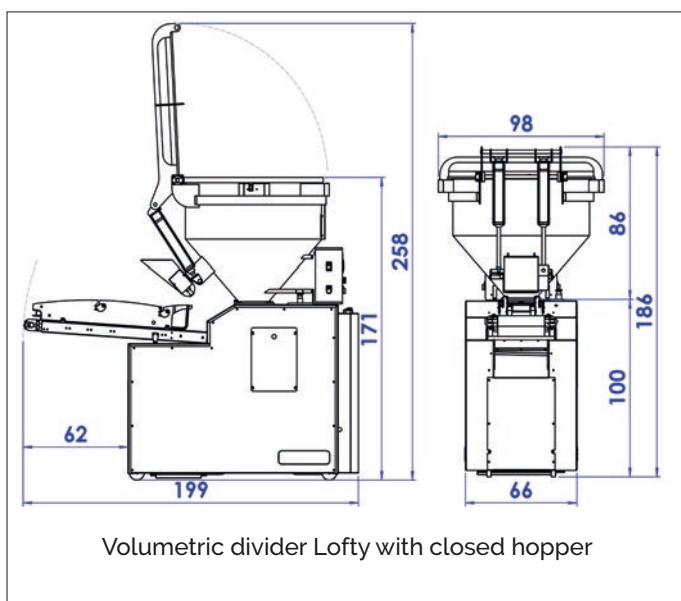

### WEIGHT - PACKAGING DIMENSIONS

Net weight of volumetric divider without hopper: 520kg

#### LOFTY with pressure hopper (2 parcels), wooden crate:

no. 1 wooden crate - 204 x 74 x 160 cm - 530 kg (for divider without hopper)

no. 1 wooden crate - 127 x 109 x 121 cm - 130 kg (for pressure hopper)

#### LOFTY with open hopper 160kg (2 parcels), wooden crate:

no. 1 wooden crate - 204 x 74 x 160 cm - 530 kg (for divider without hopper)

n°2 wooden crate (only for hopper 160kg) 120x120x84cm (LxH), 100 kgs

### ELECTRIC SPECIFICATIONS

Power supply: 400 V

Primary motor power: 2,5 kW

Operating frequency: 50/60 Hz

### SECURITY

The Lofty volumetric divider is in accordance with:

- With 2006/42/CE the directive on hatches
- With labor code

Z.I. de la Turbanière  
BRECE • 35530 • FRANCE

+33 (0)2 99 04 15 30

salesdpt@merand.fr

www.merand.fr /en/