

DIVIDER-SHAPERS

Div'X & ATOUPAINS

DIV'X



Straight cut system



1 Standard category grid included
Ex. 10 baguettes grid, straight cut



ATOUPAINS

Système Alvéoform®



AlvéoForm® Syetem 10 baguettes:
1 V-shaped grid + 1 tray 10 cells



STANDARD

- **Aluminium tank:** no rust which means better hygiene
- **The underneath of the lid and cutters in stainless steel:** stable and high resistance for long life of the machine
- **Structure and coverings in varnished metal sheet:** robust structure, reliable
- **Lid locking pin in tempered steel in a T shape:** ensures a nice flattening of the lid to avoid leakage of the dough with guaranteed long life
- **Assistance of lid opening without spring:** lid assistance by gas jack smoothed at the end of opening to limit the shocks and without risk of breakage nor fall of the lid
- **Fast descent of the dividing blocks:** descent of the tray in 2 seconds stopwatch for a reduction of the time-outs of the baker
- **Clean-up system:** allows the access to the knives by a simple action for cleaning
- **Grid-holder:** allows the division into dough pieces of different formats with the same machine
- **QuickLock® on grid-holder:** automatic grid holder locking system, no need to turn the handle
- **High density food-grade plastic dividing blocks:** non stick surface to avoid too much flouring
- **Optimized working ergonomics:** controls and lids at hand and working position as closely as possible to the tank for a comfort of greater work and to optimize the time of cycle
- **Side handles:** allow a movement of the machine without efforts while insuring the protection of controls
- **Powerful handle of lid:** important and ergonomic lever arm and reduction of the tightening for an effective use without efforts
- **Removable blocks by simple pin:** it allows a simple and fast dismantling to facilitate the maintenance of the machine
- **Very clear interior of the machine:** cylinder / floats / blades set suspended on the tank guarantees reliability over time, minimizes retention areas and facilitates maintenance of the interior of the divider
- **Side doors access:** allows to reach quickly and simply the inside of the machine while being secured by a locking key
- **Eco-Start system:** hydraulic pump working only in phase press or division for an energy saving and a reduction of sound transmissions

BRONZE

- **varioPRESS**: pressure regulator that allows to work very soft, hard or fat dough with the same machine. The settings of spreading pressure is accessible to the baker and is graduated to establish recipes
- **APF¹**: Flour Anti-Projection. Steel gutters welded to the cover, and therefore unalterable. This system channels the flour expelled during the compaction of the dough to reduce dust emissions into the air

SILVER

- **EasyDoor**: opening of doors without tools for optimum safety. The opening causes automatically the stop of the machine

GOLD

- **Cycl'Auto**: Press and/or Cut cycle(s) automation. The opening causes automatically the stop of the machine

PLATINUM

- **AutoFlour**: homogeneous automatic and adjustable flouring of the bottom of the tank and the top of the dough block

	STANDARD	BRONZE	SILVER	GOLD	PLATINUM
varioPRESS		✓	✓	✓	✓
APF ¹		✓	✓	✓	✓
EasyDoor			✓	✓	✓
Cycl'Auto				✓	✓
AutoFlour					✓

OPTIONS

- **FlexiTable**: folding side table. This shelf positioned to the right of the press allows you to place dough or other plates. It can be folded down with one click to adapt to needs even in tight spaces
- **FlourBox**: flour container on integrated support as close as possible to the tank, removable, flouring at hand
- **BlockForm**: dough block sizing tool. Give your dough blocks the right dimensions so you don't have to touch them again, and therefore degas them
- **Teflon-coated stainless steel grids**: nearly 100 models available (catalog on request)
- Version with stainless steel frame and casing
- **PressPlat**: pressing plate which makes it possible to carry the dough pieces divided with the grid holder (by sliding it under the felt after division), or to press fat without having the marks of the cutters
- **Aivéo Form** plate: returned this plate will offer you these same functions

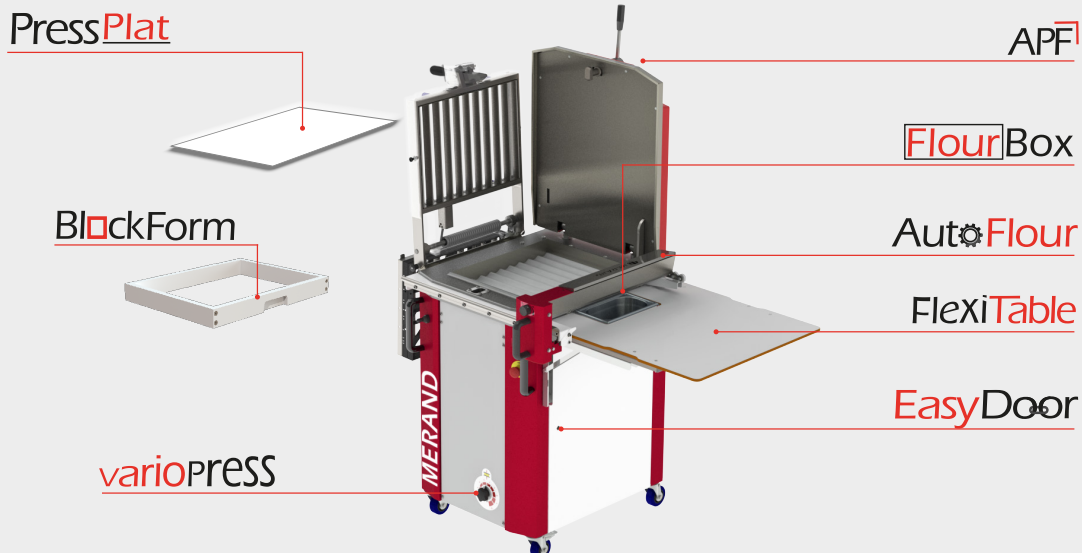

STRAIGHT CUT SYSTEM VS ALVÉOFORM SYSTEM

Div'X® Straight cut system



This system is equipped with straight cutting blades that slice the dough leaving the sides open. These grids are available at MERAND in nearly 100 different models allowing square, rectangular, triangular and even round divisions.



ATOUPAINS Alvéoform® system



This patented system consists of 1 V-shaped grid + 1 tray 10 cells

- *Round and square ends*
- *More rounded baguettes*
- *Without slicing marks on the sides*



GRID HOLDER FEATURES

- **Grid mounted on spring-dampers:** whatever the model of the grid, it allows a perfect dough pieces cut
- **Built-in grid storage support:** it allows storing of up to 3 grids without increasing the machine dimensions
- **Security and visibility:** the grid holder is completely secured by a housing. The latter is transparent in order to visualize the division process and thus to control it
- **Grid holder in different dimensions:** dough division into different shapes with the same machine
- **Quick grid changing system:** thanks to the automatic lock, the change of grid is simple and fast
- **Folding grid hold:** the grid holder is foldable with the help of 2 built-in locks. This makes it possible to use, for example, the classic 20-division machine to the right of a manual proofer without being constrained by the grid holder

OVERALL DIMENSIONS

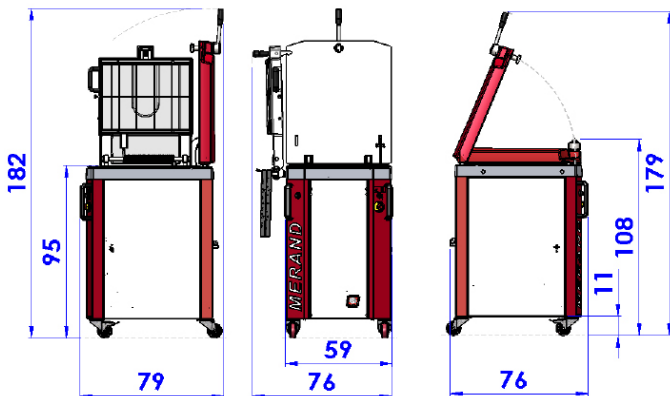

ELECTRICAL FEATURES

Global electric power: 1,5 kW maxi à 50Hz
1,8 kW maxi à 60Hz

Voltage: 400 V / 230V tri
Intensity: 4,5 A / 7,8 A
Frequency: 50 Hz / 60 Hz
Protection: IP54

WEIGHT / PACKING

Net weight: 260kg
Packed weight in cardboard box: 284kg
Packed weight in wooden crate: 322kg
Pallet and cardboard box dimensions:
Length: 100cm Width: 92cm Height: 136cm
Dimensions palette et caisse bois :
Length: 108cm Width: 106cm Height: 140cm

CAPACITIES

Capacity of the tank in dough weight:

- 1 kg minimum
- 20 kg maximum

Information given for information purposes may vary according to the nature of the dough

SECURITY

The DIVA presses are conform to:

- The machine directive 2006/42/CE
- The labor law

Z.I. de la Turbanière
BRECE • 35530 • FRANCE

+33 (0)2 99 04 15 30

salesdpt@merand.fr

www.merand.fr/en/