

# INTERMEDIATE PROOFER

## BMF COMPACT model with automatic loading

### USE

Machine allowing a rest of the dough pieces, with automatic loading from a weighing divider and automatic output to a moulder.

### CAPACITIES (\*)

Model	Number of pockets total	Number of useful pockets	swing total	Larger of the swing	Max weigh/pocket
BMF-COM-73/57/8	632	456	73	140	550g
BMF-COM-73/57/7	559	399	73	140	650g
BMF-COM-59/46/7	413	322	59	170	700g
BMF-COM-59/46/6	354	276	59	170	800g
BMF-COM-59/46/5	295	230	59	170	1000g

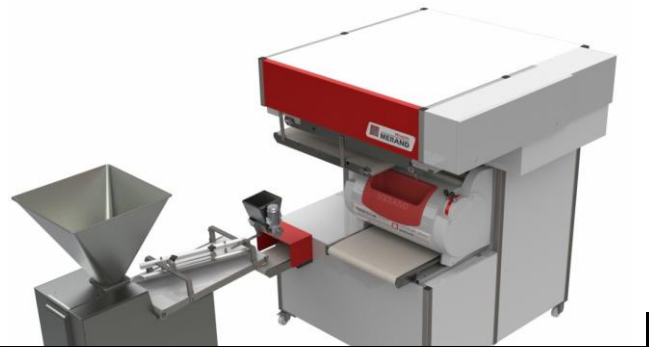

(\*) : Information given as an indication for passage into the weigher without fermentation in the mixer. They can vary according to the nature of the dough (% of yeast, temperature of the dough, temperature of the local, time of fermentation)

### FEATURES

**Structure made of mechanically welded tubular steel.** Optimum strength and rigidity.

#### Dough balls loader

Loader equipped with an entry cone and a horizontal curved belt. It allows the loading and preserve the dough pre-balls.

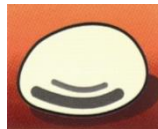

#### Modularity of the configurations

Can adapt to your local and your working methods.

#### Machine monted on 4 wheels, 2 with brakes.

Easy to move due to the wheels Ø80 polyamides.

#### Intermediate Proofer totally enclosed.

Panels in Dibond ® unalterable and covers are in painted sheets. Safety and hygiene optimum.

#### Ultra Violets Lamps

Germicidal action with automatic timer.

#### Speed variator

Allows to adapts the speed of the output conveyors to the pace of the work ( maxi 1800 pieces of dough / hour).

#### Modulo-clips®

Allows you to change the capacity of your swing in the future (see table capacity), without changing the frames (5 to 7 pockets).

#### Loading selector of the number of pockets.

Allowed to load all the pockets of the frame, on less or two less. This allows to adjust the resting time according to the cadence.

### OPTIONS

#### Second transfer belt 0,75m or 1m

Allows to feed a second moulder with direction reversal of the output belt.

#### Pack Pro (4 ventilators + humidity extractor)

Allowing the drying process of the gutters during the automatic cycle germicidal cleaning.



# PRESENTATION

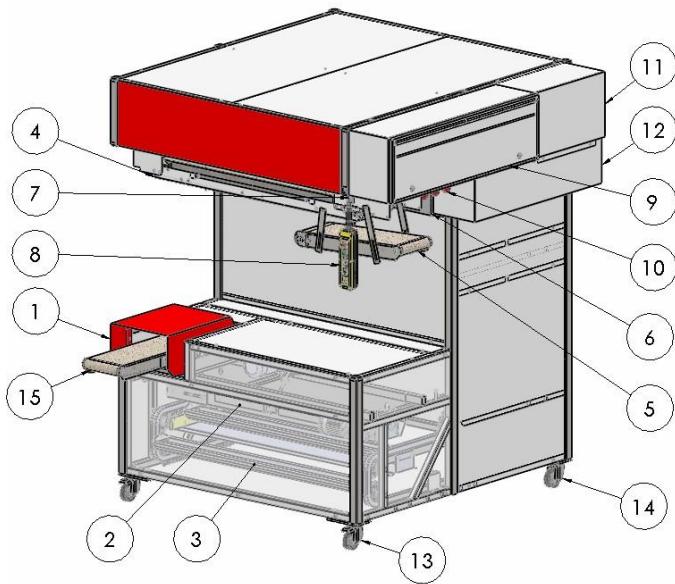

- 1- Access trapdoor of the loading area
- 2- Loading dispatcher in « V »
- 3- Swing equipped with modulo clips®
- 4- Output belt
- 5- Transfer belt length 0,75m or 1m
- 6- Germicidal equipped with a Ultra Violet lamp
- 7- Potence for the box commands
- 8- Box commands
- 9- electrical cabinet
- 10- 3 electrical plug for connecting the weigher, the moulder and the evacuation belt
- 11- Motor housing
- 12- Wire housing
- 13- 2 wheels brakes Ø80
- 14- 2 wheels Ø80
- 15- Loader of dough balls feeding belt

# DIMENSION

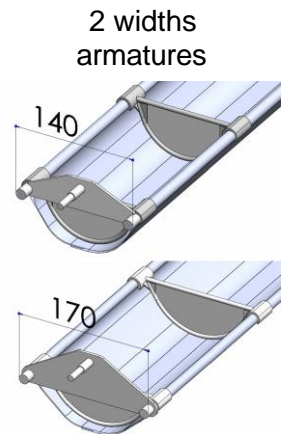
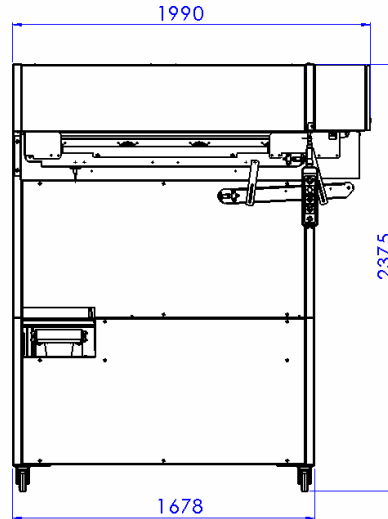
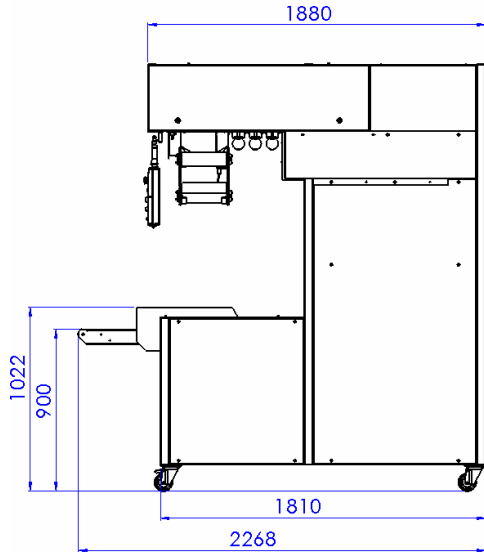

## WEIGHING — PACKING

Model	Weigh in Kg
BMF COMPACT	600

## ELECTRICAL CHARACTERISTICS

- 400 Volts / 50 Hz / 1,5 kW max. / 10 A max.
- 400 Volts / 60 Hz / 1,8 kW max. / 10 A max.
- 230 Volts / 50 Hz / 1,5 kW max. / 17 A max.
- 230 Volts / 60 Hz / 1,8 kW max. / 17 A max.

Supply : 5 M cable with plug male TRI + T + N

## HYGIENE — SECURITY

The intermediate Proofer BMF COMPACT is conforms :

- At the machinery directive 2006/42/CE
- To the Labour Code.

Distributed by :



MÉRAND Mécapâte S.A. ■ Z.I. de la Turbanière ■ BRÉCÉ ■ 35530 NOYAL SUR VILAINE ■ FRANCE  
 ☎ + 33 (0)2 99 04 15 30 ■ Fax + 33 (0)2 99 04 15 31 ■ internet : <http://www.merand.fr>