

MANUAL PROOFER

USE

Machine that allows dough pieces resting

CAPACITES (*)

Model	N° of swings	Width of swings	Capacity of baguettes 320g*	Capacity in breads 550g*	Capacity in breads 900g*
PAGE 26 / 140	26	140	260	208	
PAGE 20 / 170	20	170	200	160	140
PAGE 33 / 140	33	140	330	264	
PAGE 26 / 170	26	170	260	208	182
PAGE 40 / 140	40	140	400	320	
PAGE 32 / 170	32	170	320	256	224

(*) : Informations given as an indication only and can vary depending on type of dough..



FEATURES

Little cluttering for maximum capacity.
Complete optimization of space in workshop.

Work is done at ergonomic height
- Height for moulding table : 93 cm
- Height for rounding table : 83 cm

Machine on 4 wheels including 2 with breaks.
Easy to move thanks to polyamide wheels Ø80.

Structure made of steel sheeting 20/10th double thickness on sides.
Optimal shock resistance and rigidity.

Inside of sides with flat surface.
No flour dust

Swing trays working with pulse pedal.
Very simple to use and ergonomic.
Allows lcontinuous oading of the moulder.

Nyltex® pockets double thickness without velcro.
Super resistant pockets in a fabric that holds little humidity and with no bacteria area.

Washable Nyltex® pockets.
Can be removed easily for cleaning.

If failure of the system, possibility to use back up system
Allows to empty proofer is electricity cut.

Casing to plug in moulder and divider.
For other linked machines.

Electric casing separate from motor unit.
Allows access to the mechanical areas without electric shock risk for users.

Strong mechanical screw.
Guarantees the mechanical protection of the machine.

OPTIONS

Rounding table covered in felt.
Reinforced structure.
Foldable and can be handled with one hand.

Hygiene kit (UV lamps + air extractor) UV
lamps with anti germ action.
Air extractor for drying of the pockets

Dividing clips.
Divides the pockets individually.

Pedal with impulse
Complete the advance by push buttons. Can be positioned as you wish in front of the machine

PRESENTATION

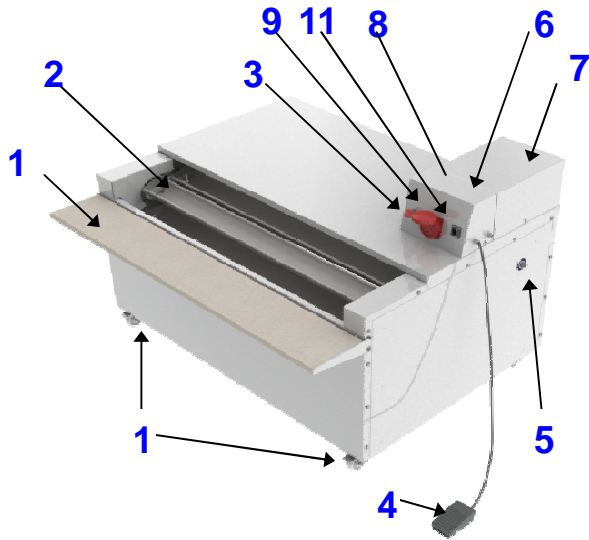

- | |
|----------------------|
| 1-Wheel brake |
| 2-Proofer |
| 3-On/off button |
| 4-Pedal with impulse |
| 5-Manual impulse |
| 6-Electric cabinet |
| 7-Engine compartment |
| 8-Connecting device |
| 9-Connecting socket |
| 10-Rounding table |
| 11-Germicide switch |

DIMENSIONS

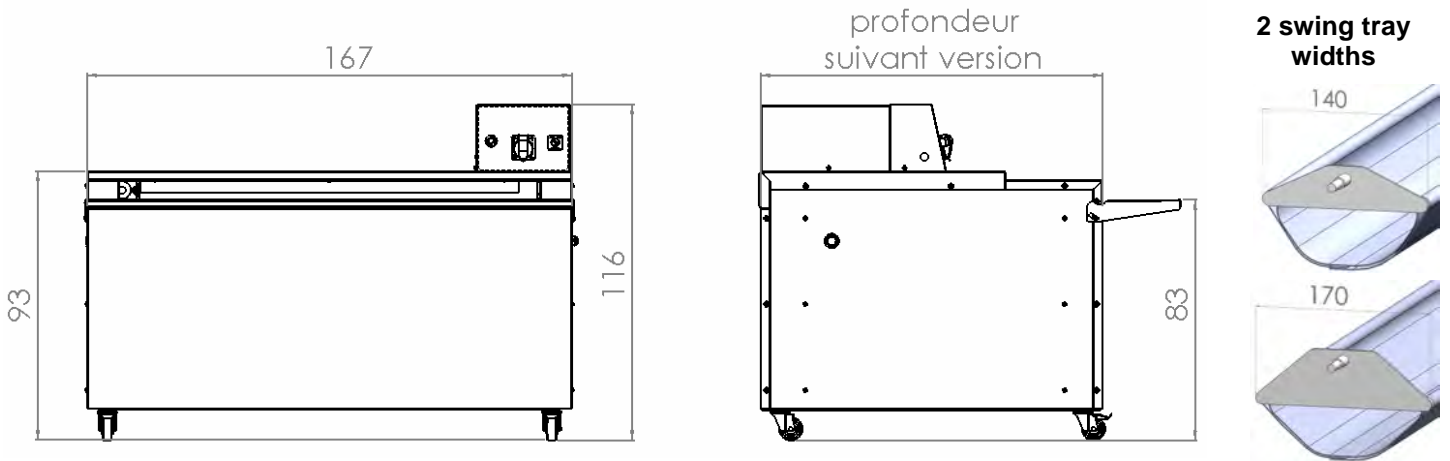

WEIGHT—PACKING LIST

Model	N° of swings	Width of swing trays	Depth in cm	Weight when empty
PAGE 26 / 140	26	140	98	266 Kg
PAGE 20 / 170	20	170	98	252 Kg
PAGE 33 / 140	33	140	118	300 Kg
PAGE 26 / 170	26	170	118	283 Kg
PAGE 40 / 140	40	140	137	333 Kg
PAGE 32 / 170	32	170	137	315 Kg

Crate : weight : 45kgs
L/D/H : 124/84/189 cms

ELECTRICAL FEATURES

- 400 Volts / 50 Hz / 0,25 Kw / 0,9 A
 - 400 Volts / 60 Hz / 0,24 Kw / 0,85 A
 - 230 Volts / 50 Hz / 0,25 Kw / 1,56 A
 - 230 Volts / 60 Hz / 0,24 Kw / 1,47 A
- Electricity supply : 5 m cable with male plug TRI + T + N*

HYGIENE — SECURITY

- Conforms to :
- Machine directive 2006/42/CE
 - French work code.



Distributed by :