

ARMOR UNIVERSAL Model + Baking trays on deposit

USE

- To shape doughballs from 200 gr to 1.5kgs.
- Production rate : up to 1800 doughballs / hour as per the weight of the doughballs.
- Possibility to cut dough pieces with pre-elongated shape.
- Automatic removal on baking trays of various sizes (max 800/1000) without any modification.

FEATURES

Front Feed Belt.

Easier for the introduction of doughballs inside the laminating system by increasing the capacity of production and preparing the dough to the sheeting rolling.

Pre-rolling System and sheeting rolling (which from **Alvéo+®**)

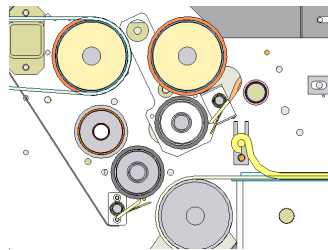

A gradual sheeting rolling for a better moulding (1 roll of pre-rolling **Alvéo+®** to preserve the alveolus structure of the soft part by reducing the degassing, and 5 rolls of laminating).

Motorized Flouring :

Doughball flouring is realized between the pre-elongation and the final elongation to avoid sticking and to get a better doughball final aspect.

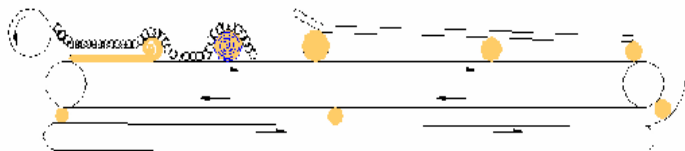

2 Stretching systems :

- Superior stretching with loadsizing of doughballs.
- Inferior stretching on belt with 3 positions with the C2A system (controlled system stretching).



Cutting system of rolls **Rolls-coup® Adjustable** (stretching of baguette and then cutting in 2, 3, 4, 5 or 6).

Retrieval system of extremities to assure regular lengths and weights.

3 pairs of **Rolls-coup** are included with the machine. Additional pairs are on .

Spacer system of moulded rolls (after cutting operation).

To avoid that doughballs are stucked each other in trays.

Automatic Deposit on trays.

Adjustables sizes to accept any size of mecanized trays.

V-shaped loading guide which requires compressed air.

To assure the right position of moulded dough balls (or cut) in trays.

Pointop sytem for sharp ends : **Pointop®**.



Can easily be put between the 2 moulders belts to get the length bread required.

ACCESSORIES — OPTIONS

- Stabilizer : to allow the moulded dough balls on one side of the tray to make easier the automatic scoring

PRESENTATION

DIMENSION

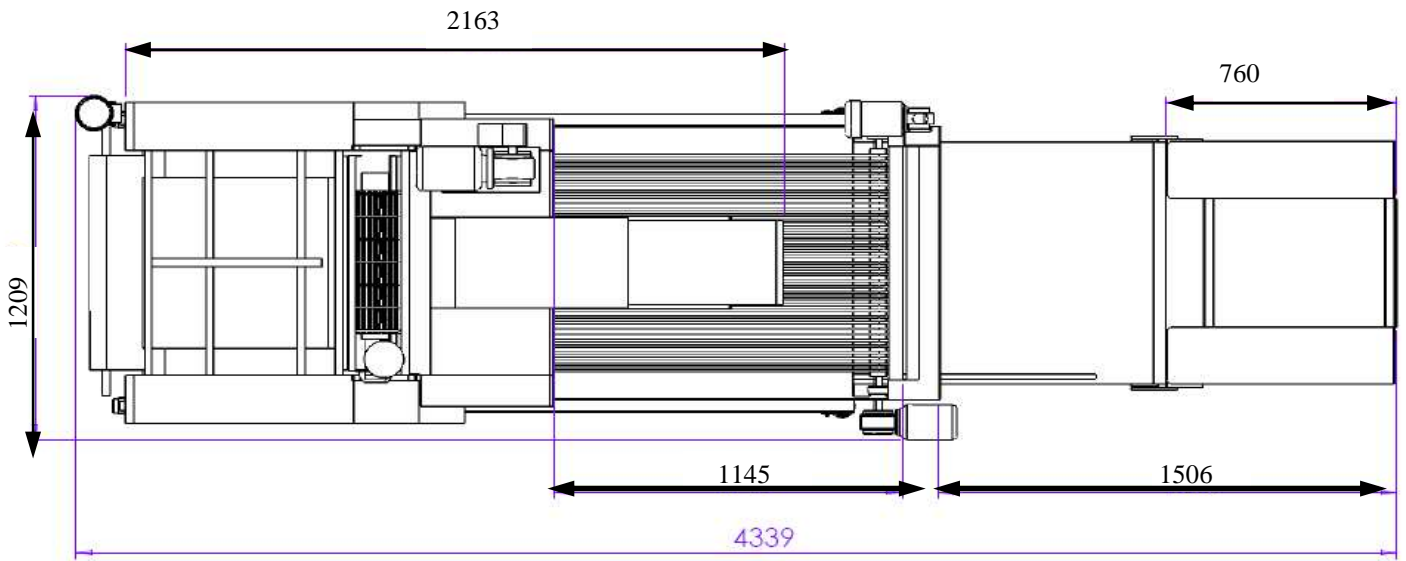

ARMOR U ON DEPOSIT

WEIGHT — PACKING

Packing on slatted outer carton pallet :
 Net weight : 375 Kg
 Dimensions (Length X Width X Height) :
 1,5 m X 1,4 m X 0,8 m.

Packing on slatted wood box pallet () :*
 Gross weight : 425 Kg
 Dimensions (Length X Width X Height) :
 1,5 m X 1,4 m X 0,8 m.

(*) Maritime full box, non treated wood

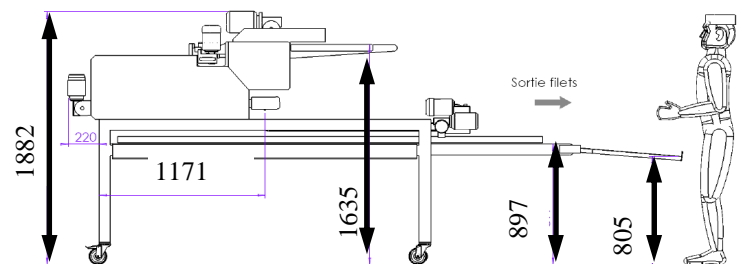

ELECTRICAL FEATURES

- 380 Volts / 50 Hz / 0,92 Kw / 2,95 A
 - 380 Volts / 60 Hz / 0,92 Kw / 2,95 A
 - 220 Volts / 50 Hz / 0,92 Kw / 4,2 A
 - 220 Volts / 60 Hz / 0,92 Kw / 4,2 A
- Power supply : cable of 4 m with plug sorting TRI+T+N.

HYGIENE — SECURITY

The moulding Armor Universelle is in accordance with :

- 89/392 ECC, the directives on hatches.
- The labour regulation.



Distributed by :