



MERAND Mécapâte S.A

Z.I de la Turbanière B.P 93329 Brécé
35533 Noyal sur Vilaine FRANCE

Tel: +33.2.99.04.15.30 - Fax: +33.2.99.04.15.31
salesdpt@merand.fr

www.merand.fr

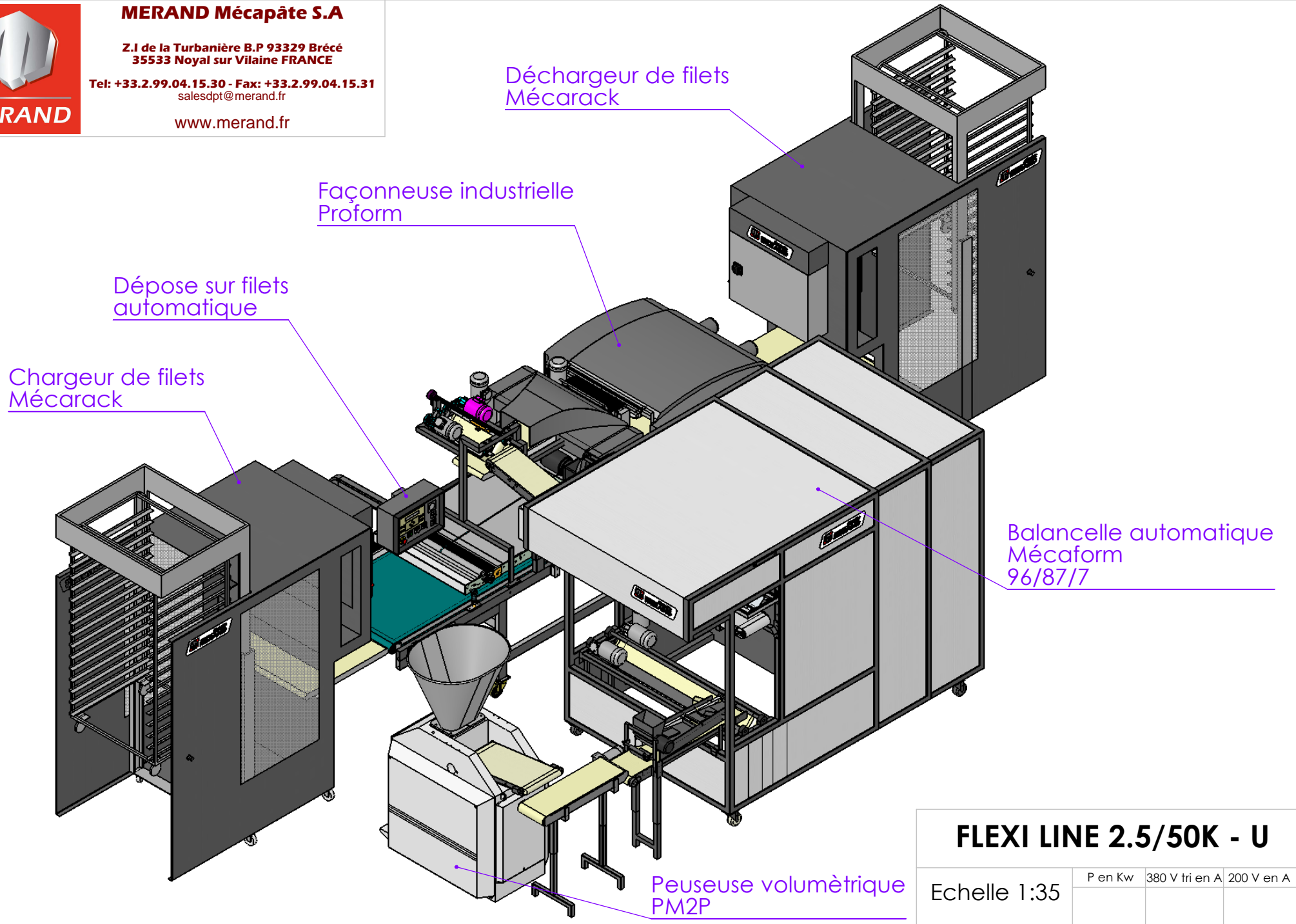

FLEXI LINE 2.5/50K - U

Echelle 1:35

P en Kw	380 V tri en A	200 V en A
---------	----------------	------------



MERAND

MERAND Mécapâte S.A

Z.I de la Turbanière B.P 93329 Brécé
35533 Noyal sur Vilaine FRANCE

Tel: +33.2.99.04.15.30 - Fax: +33.2.99.04.15.31
salesdpt@merand.fr

www.merand.fr

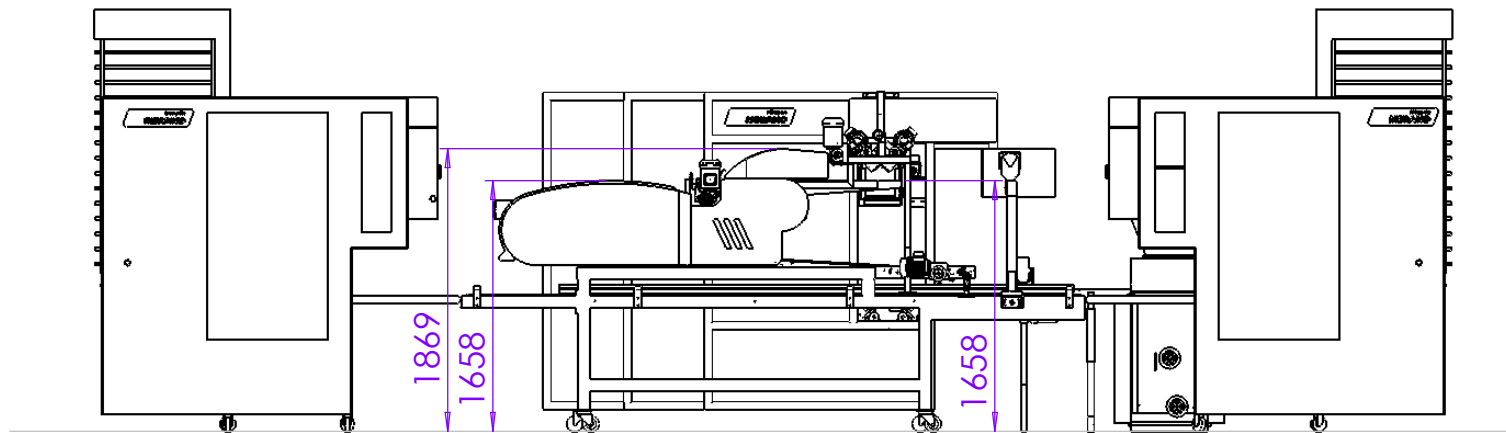
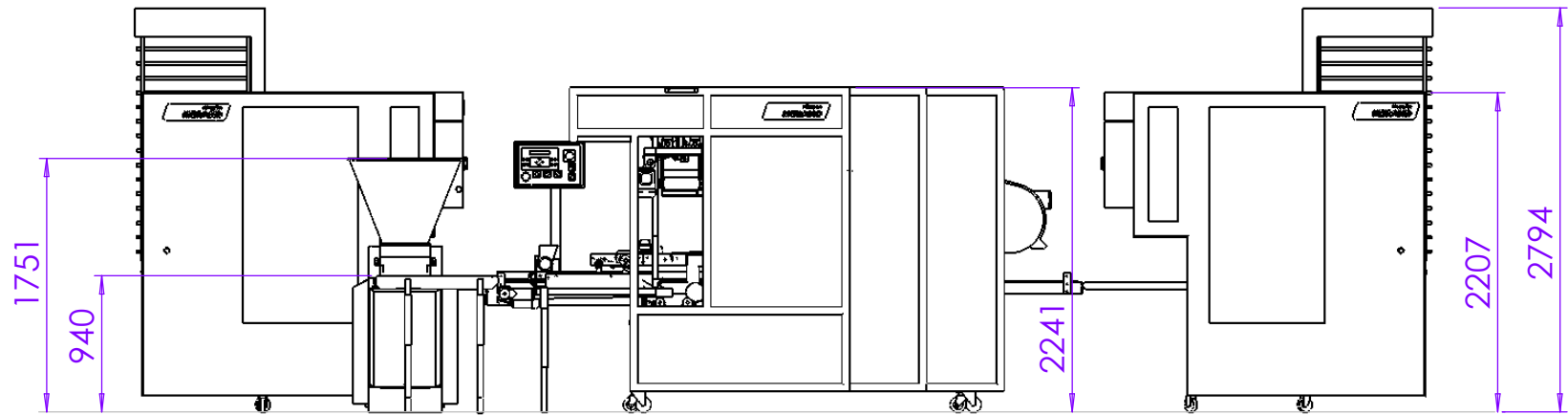

FLEXI LINE 2.5/50K - U

Echelle 1:50	P en Kw	380 V tri en A	200 V en A