

## VERTICAL MOULDER **TREGOR TRADITION (FVTT)**

### USE

- Machine to roll and shape dough balls.
- Weight from 30 grams (1.05 oz) to 1 450 grams (3.19 lb)
- Production rate : up to 1 850 pieces per hour according to dough ball weight.(about 1500 baguettes per hour).

### FEATURES

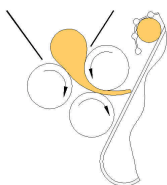

**3 rollers with the PPR system (adjustable Progressive Prelaminating.) and the Alvéo+® PPR system** : A gradual laminating for a better shaping (a pre-laminating roller + 2 laminating rollers.)

**Alvéo+®** : 3 rollers of the same diameter, one of which has a specific design which means the air structure of the dough pieces is retained as well as if done by hand.

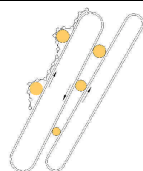

**Stretching system between 2 moving belts(machine compact).**

Good stretching, dough balls make many turns in the machine and are well rolled up.

**Food aluminium sides (12 mm thick) assure the preservation of fundamental factory adjustments such as:**

- The parallelism between rollers.
- The toe in angle and the angle between the 2belts

**Easy dismantling of the 2 belts within 25 mn, 5 mn for the back belt :**

- Easier maintenance.
- Lower intervention costs for the customer.
- Saving of time for the engineer.

**Hinged safety hopper, and easy removable scrapers:**

- Easy access for the maintenance.
- Easy scrapers dismantling for the cleaning.
- Easier maintenance, higher roller longevity.



**7 mm thick woven wool belt:**

- Better shaping and better aspect of the shaped dough balls.
- Good support of the belts during the shaping and a higher equipment longevity.

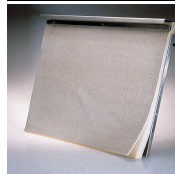

**Pointop® system included**

For automatic processing of baguettes and breads with sharp ends.

**2 selectors with timekeepers for adjusting dough laminating and stretching processes.**

This feature allows for more accurate and reliable adjustments.

### ACCESSORIES — OPTIONS

- Handle control on the left (must be specified in the order form).
- Rolling stand
- Feed belt (advised for a feeding by intermediate proofer).
- Fitting kit on already existing discharge belt.
- Guide for square breads, hot dog buns, rolls.
- **Rolls-coup® system** : automatic cutting of a baguette into rolls (Different versions available depending on the type desired).

## PRESENTATION



- 1—Stretching adjustment.
- 2—Laminating adjustment.
- 3—Safety hopper.
- 4—Reception flap belt.
- 5—Shaping belt (light or heavy).
- 6—Switch 0—1—Start.

## OVERALL DIMENSIONS

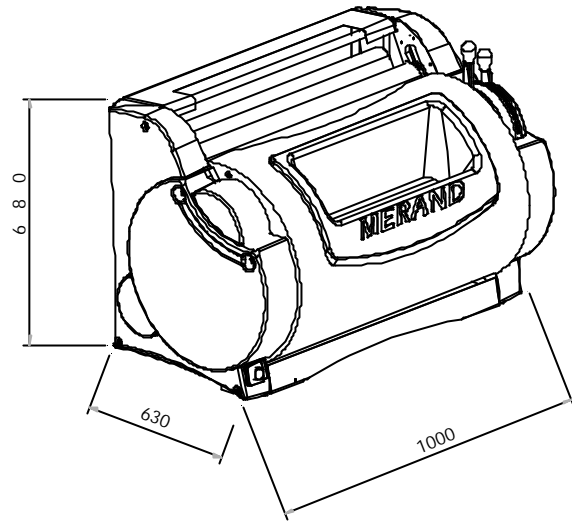

Discharge flap belt depth: 830 mm (2.1/2 f.)

Moulder's support fixation footings on rolling stand or discharge belt : 900 mm (2.7 f.)

## WEIGHT AND PACKAGE DIMENSIONS

Net weight : 165 Kg (363 lb)

*Packaging on slatted outer carton pallet two way :*

Gross weight : 180 Kg (396 lb)

Dimensions (Length X Width X Height) : 1,05m X 0,90m X 0,90m.

*Packaging on slatted wood box pallet two way :*

Gross weight : 230 Kg (506 lb)

Dimensions (Length X Width X Height) : 1,05m X 0,90m X 0,90m.

(\* Maritime full box, non-treated wood)

## ELECTRIC SPECIFICATIONS

- 380 Volts / 50 Hz / 0,55Kw / 1,75 A
- 380 Volts / 60 Hz / 0,55 Kw / 1,75 A
- 220 Volts / 50 Hz / 0,55 Kw / 2,90 A
- 220 Volts / 60 Hz / 0,55 Kw / 2,90 A

Power supply : cable of 4m with plug SORTING + T + N

Rotation engine speed :

- 880 revs/mn in 50 Hz
- 1080 revs/mn in 60 Hz



Distributed by :

## HYGIENE — SECURITY

The Trégor moulder is in accordance :

- with the 89/392 EEC directive on hatches.
- with the labour regulations.