

VERTICAL MOULDER TREGOR PPR (FVTR)

USE

- Machine to roll and shape dough balls.
- Weight from 30 grams (1.05 oz) to 1 450 grams (3.19 lb).
- Production rate : up to 1 800 pieces per hour according to dough ball weight.(about 1 500 baguettes per hour).

FEATURES



Pre-laminating and laminating system between 3 rollers: PPR (Adjustable Progressive Prelaminating.)

A gradual laminating for a better shaping (a pre-laminating roller + 2 laminating rollers.)

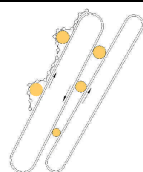

Stretching system between 2 moving belts(machine compact).

Good stretching, dough balls make many turns in the machine and are well rolled up.

Food aluminium sides (12 mm thick) assure the preservation of fundamental factory adjustments such as:

- The parallelism between rollers.
- The toe in angle and the angle between the 2belts

Easy dismantling of the 2 belts within 25 mn, 5 mn for the back belt :

- Easier maintenance.
- Lower intervention costs for the customer.
- Saving of time for the engineer.

Hinged safety hopper, and easy removable scrapers:

- Easy access for the maintenance.
- Easy scrapers dismantling for the cleaning.
- Easier maintenance, higher roller longevity.

2 selectors with timekeepers for adjusting dough laminating and stretching processes.

This feature allows for more accurate and reliable adjustments.



7 mm thick woven wool belt:

- Better shaping and better aspect of the shaped dough balls.
- Good support of the belts during the shaping and a higher equipment longevity.

ACCESSORIES — OPTIONS

- Handle control on the left (must be specified in the order form).
- Rolling stand.
- Feed belt (advised for a feeding by an intermediate proofer).
- Fitting kit on already existing discharge belt.
- Guide for square breads, hot dog buns, rolls.
- **Pointop® system** : automatic processing of baguettes and breads with sharp ends.
- **Rolls-coup® system** : automatic cutting of a baguette into rolls (Different versions available depending on the type desired).

PRESENTATION



- 1—Stretching adjustment.
- 2—Laminating adjustment.
- 3—Safety hopper.
- 4—Reception flap belt.
- 5—Shaping belt (light or heavy).
- 6—Switch 0—1—Start.

OVERALL DIMENSIONS

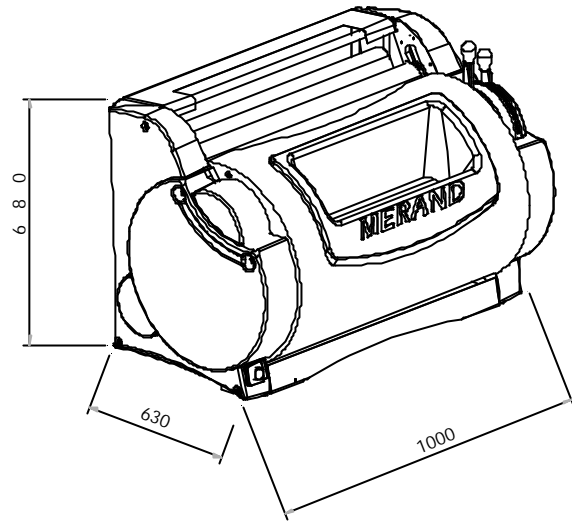

Discharge flap belt depth: 830 mm (2.1/2 f.)

Moulder's support fixation footings on rolling stand or discharge belt : 900 mm (2.7 f.)

WEIGHT AND PACKAGE DIMENSIONS

Net weight : 165 Kg (363 lb)

Packaging on slatted outer carton pallet two way :

Gross weight : 180 Kg (396 lb)

Dimensions (Length X Width X Height) :
1,05m X 0,90m X 0,90m.(3.4 f x 2.9 f x 2.9 f)

Packaging on slatted wood box pallet two way :

Gross weight : 230 Kg (506 lb)

Dimensions (Length X Width X Height) : 1,05m
X 0,90m X 0,90m.

(* Maritime full box, non-treated wood)

ELECTRIC SPECIFICATIONS

- 380 Volts / 50 Hz / 0,55Kw / 1,75 A
- 380 Volts / 60 Hz / 0,55 Kw / 1,75 A
- 220 Volts / 50 Hz / 0,55 Kw / 2,90 A
- 220 Volts / 60 Hz / 0,55 Kw / 2,90 A

Power supply : cable of 4m with plug SORTING + T + N

Rotation engine speed :

- 880 revs/mn in 50 Hz
- 1080 revs/mn in 60 Hz



Distributed by par :

HYGIENE — SECURITY

The Trégor moulder is in accordance :

- with the 89/392 EEC directive on haches.
- with the labour regulations.