

## VERTICAL MOULDER **TENOR 3 (FVTE-3)**

### USE

- Machine to roll and to shape dough balls.
- Weight from 50 grams (1.76 oz) to 1 450 grams (3.19 lb)
- Production rate: up to 1 800 parts per hour depending on the dough ball weight (about 1500 baguettes per hour)

### FEATURES

#### **Laminating system between 3 rollers.**



A gradual laminating for a better shaping (a pre-laminating roller + 2 laminating rollers)

#### **Stretching system between two moving belts (compact machine).**



Good stretching, dough balls make many turns in the machine and are well rolled up.

#### **Food aluminium sides (12 mm thick) assure the preservation of fundamental factory adjustments such as :**

- The parallelism between rollers.
- The toe in angle and the angle between the 2 belts .

#### **Easy dismantling of the 2 belts within 25 mn, 5 mn for the back belt :**

- Easier maintenance.
- Lower intervention costs for the customer.
- Saving of time for the engineer.

#### **Hinged safety hopper, and easy removable scrapers:**

- Easy access for the maintenance.
- Easy scrapers dismantling for the cleaning.
- Easier maintenance, higher roller longevity.



#### **7 mm thick woven wool belt:**

- Better shaping and better aspect of the shaped dough balls.
- Good support of the belts during the shaping and a higher equipment longevity.

### ACCESSORIES — OPTIONS

- Handle control on the left (must be specified in the order form).
- Rolling stand.
- Feed belt (advised for a feeding by an intermediate proofer).
- Fitting kit on already existing discharge belt
- Guide for square breads, hot dog buns, rolls.

## PRESENTATION



- 1-Stretching adjustment.
- 2-Laminating adjustment.
- 3-Safety hopper.
- 4-Reception flap belt.
- 5-Shaping belt (light or heavy).
- 6-Rolling stand (option).

## WEIGHT AND PACKAGE DIMENSIONS

Net weight: 165 kg ( 363 lb)

*Packaging on slatted outer carton pallet two way:*

Gross weight: 180 kg ( 396 lb)  
 Dimensions (Length X Width X Height): 1,05m X 0,90m X 0,90m. (3.58 feet X 2.95 f X 2.95 f.)

*Packaging on slatted wood box pallet two way:*

Gross weight: 230 kg ( 506 lb)  
 Dimensions (Length X Width X Height): 1,05m X 0,90m X 0,90m.

(\* Maritime full Box, not treated wood)

## HYGIENE — SECURITY

The Ténor moulder is in accordance:

- with 89/392 EEC, the directive on hatches.
- with the labour regulations.

## OVERALL DIMENSIONS

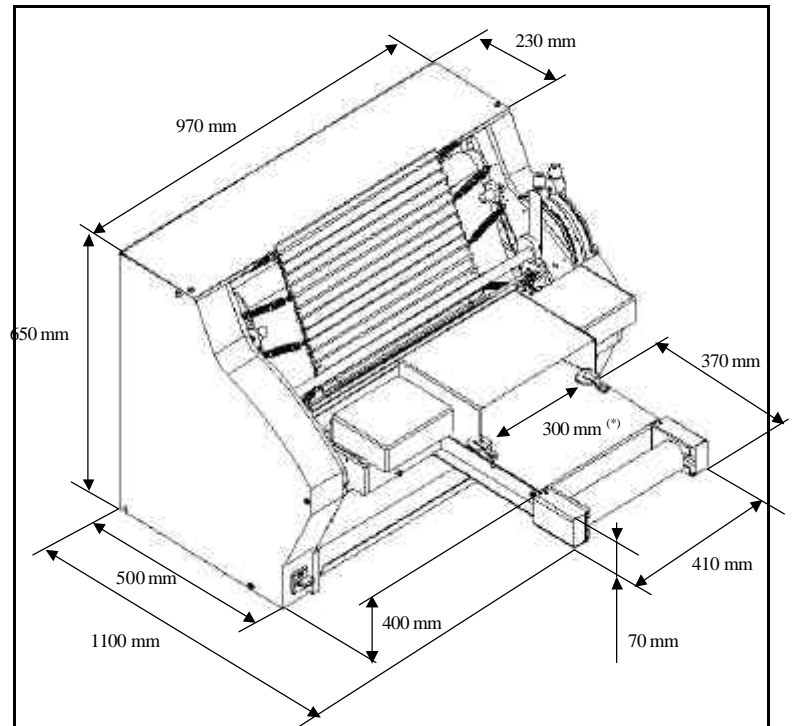

(\*): Largeur de la bande

Moulder's support fixation footings on rolling stand or discharge belt : 830 mm ( 2.1/2 f.)

Discharge belt depth : 900 mm (2.7f.)

## ELECTRIC SPECIFICATIONS

- 380 Volts / 50 Hz / 0,55Kw / 1,75 A
- 380 Volts / 60 Hz / 0,55 Kw / 1,75 A
- 220 Volts / 50 Hz / 0,55 Kw / 2,90 A
- 220 Volts / 60 Hz / 0,55 Kw / 2,90 A

*Power supply:* cable of 4m with plug SORTING + T + N  
*rotation engine speed:*

- 880 revs/mn en 50 Hz
- 1080 revs/mn en 60 Hz



Distributed by: